

Lecture – 4

Date: 11.08.2016

- Second-Order Circuit

Second-Order Circuits

- A second-order consists of resistors and the equivalent of two energy storage elements and is characterized by a second-order differential equation.

Analysis of such circuits require understanding of $v(0)$, $i(0)$, $v(\infty)$, $i(\infty)$, $dv(0)/dt$ and $di(0)/dt$

- Two key points:**

- carefully handle the polarity of voltage $v(t)$ across the capacitor and the direction of the current $i(t)$ through the inductor.
- keep in mind that the capacitor voltage is always continuous [$v(0^+) = v(0^-)$] and the inductor current is always continuous [$i(0^+) = i(0^-)$].

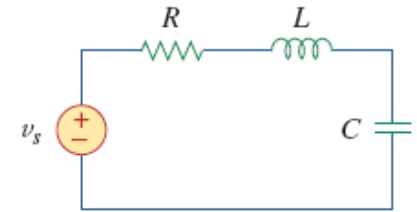

(a)

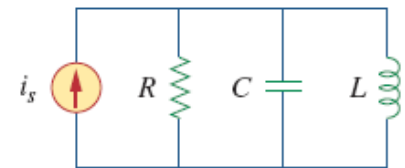

(b)

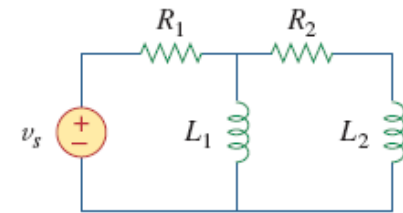

(c)

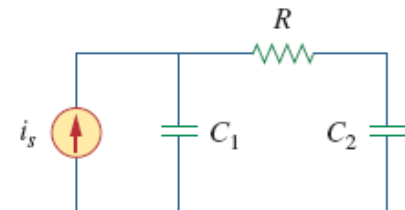

(d)

v denotes capacitor voltage, while i is the inductor current.

Example – 1

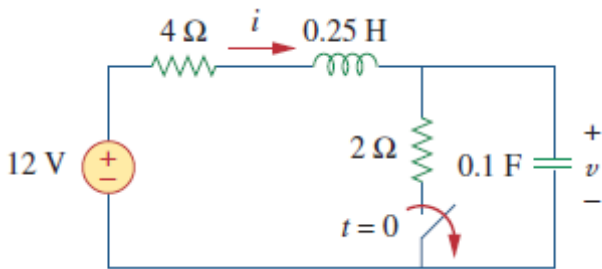

The switch in this figure has been closed for a long time. It is open at $t = 0$. Find: (a) $i(0^+)$ and $v(0^+)$, (b) $\frac{di(0^+)}{dt}$, and $\frac{dv(0^+)}{dt}$, (c) $i(\infty)$ and $v(\infty)$.

(a) If the switch is closed a long time before $t=0$, then essentially the circuit has reached dc steady state at $t=0$.

At dc steady state, the inductor acts like a short circuit, while the capacitor acts like an open circuit.

$$i(0^-) = \frac{12}{4 + 2} = 2 \text{ A} \quad v(0^-) = 2i(0^-) = 4 \text{ V}$$

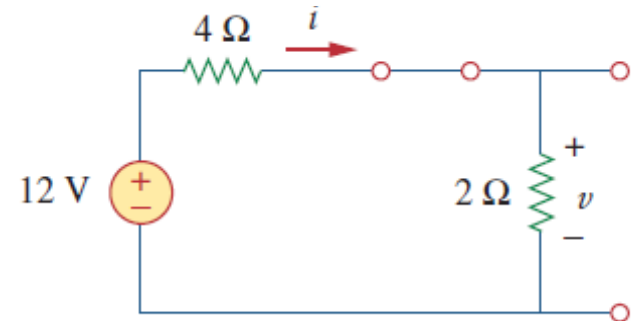

The inductor current and the capacitor voltage cannot change abruptly and therefore:

$$i(0^+) = i(0^-) = 2 \text{ A}$$

$$v(0^+) = v(0^-) = 4 \text{ V}$$

Example – 1 (contd.)

(b) At $t = 0^+$, the switch is open; the equivalent circuit will be as shown.

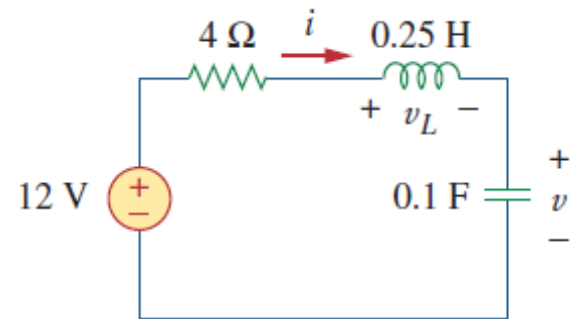

The same current flows through both the inductor and capacitor.

$$i_C(0^+) = i(0^+) = 2 \text{ A}$$

Now: $C \frac{dv}{dt} = i_C \quad \Rightarrow \quad \frac{dv}{dt} = \frac{i_C}{C} \quad \Rightarrow \quad \frac{dv(0^+)}{dt} = \frac{i_C(0^+)}{C} = \frac{2}{0.1} = 20 \text{ V/s}$

Furthermore, $L \frac{di}{dt} = v_L \quad \Rightarrow \quad \frac{di}{dt} = \frac{v_L}{L}$

From KVL: $-12 + 4i(0^+) + v_L(0^+) + v(0^+) = 0 \quad \Rightarrow \quad v_L(0^+) = 12 - 8 - 4 = 0$

$$\frac{di(0^+)}{dt} = \frac{v_L(0^+)}{L} = \frac{0}{0.25} = 0 \text{ A/s}$$

Example – 1 (contd.)

(c) For $t > 0$, the circuit undergoes transience. But as $t \rightarrow \infty$, the circuit reaches steady state again. The inductor acts like a short circuit and the capacitor like an open circuit.

$$i(\infty) = 0 \text{ A}, \quad v(\infty) = 12 \text{ V}$$

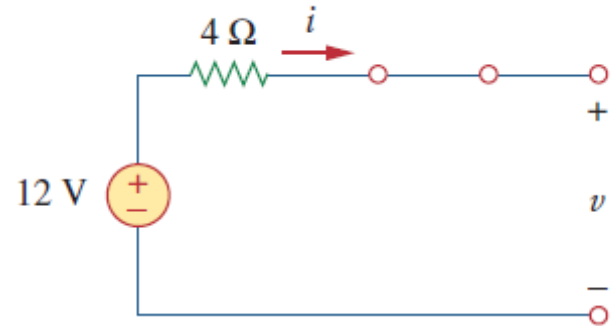

Example – 2

For the following circuit, determine:

- (a) $i(0^+)$ and $v(0^+)$,
- (b) $di(0^+)/dt$ and $dv(0^+)/dt$,
- (c) $i(\infty)$ and $v(\infty)$.

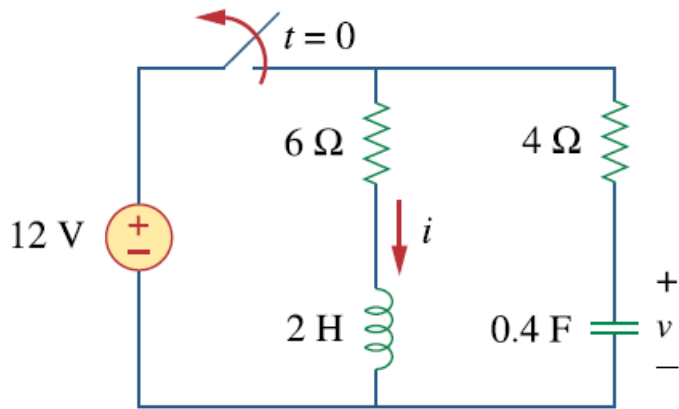

Example – 3

For the following circuit, determine:

- (a) $i_R(0^+)$, $i_L(0^+)$, and $i_C(0^+)$,
- (b) $di_R(0^+)/dt$, $di_L(0^+)/dt$, and $di_C(0^+)/dt$,
- (c) $i_R(\infty)$, $i_L(\infty)$, and $i_C(\infty)$.

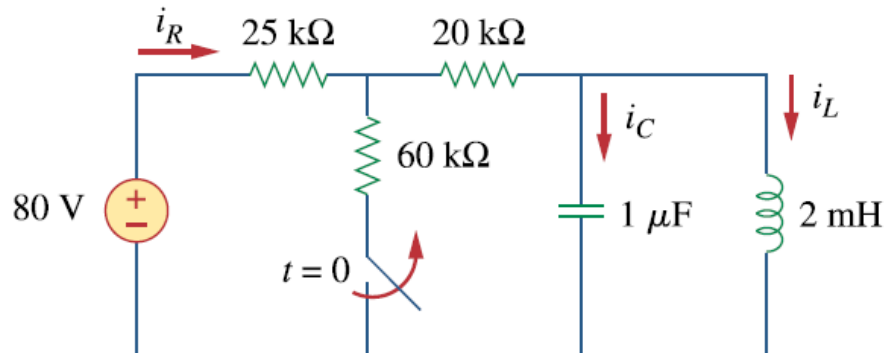

Example – 4

For the following circuit, determine:

- (a) $i_L(0^+)$, $v_c(0^+)$ and $v_R(0^+)$,
- (b) $di_L(0^+)/dt$, $dv_c(0^+)/dt$, and $dv_R(0^+)/dt$,
- (c) $i_L(\infty)$, $v_c(\infty)$ and $v_R(\infty)$

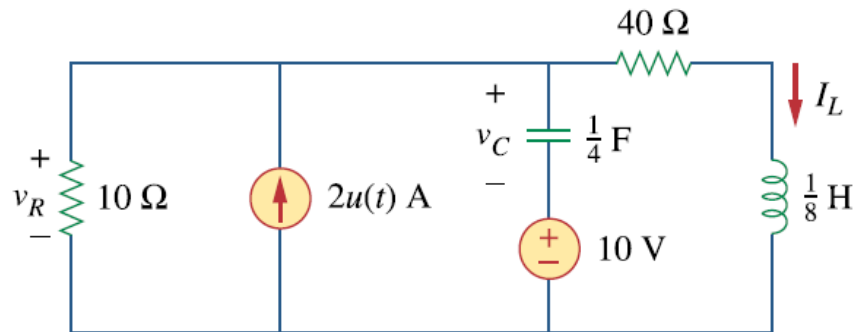

Example – 5

For the following circuit, determine:

- (a) $v(0^+)$ and $i(0^+)$,
- (b) $dv(0^+)/dt$ and $di(0^+)/dt$,
- (c) $v(\infty)$ and $i(\infty)$.

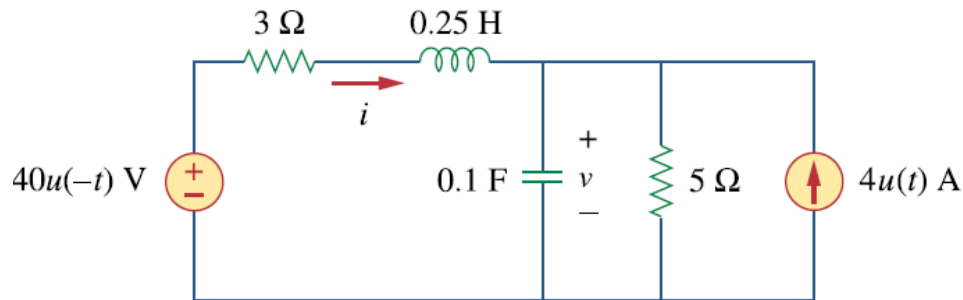

Source Free RLC Circuit

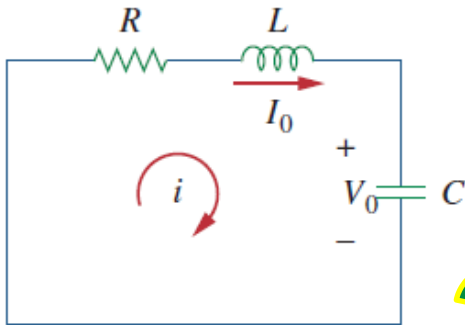

- The circuit is being excited by the energy initially stored in the capacitor and inductor.
- The energy is represented by the initial capacitor voltage V_0 and initial inductor current I_0 .

$$v(0) = \frac{1}{C} \int_{-\infty}^0 i dt = V_0$$

$$i(0) = I_0$$

- KVL around the loop

$$Ri + L \frac{di}{dt} + \frac{1}{C} \int_{-\infty}^t i(\tau) d\tau = 0 \quad \longrightarrow \quad \frac{d^2i}{dt^2} + \frac{R}{L} \frac{di}{dt} + \frac{i}{LC} = 0$$

a second-order differential equation

Substitutions

Solution of the form: $i = Ae^{st}$

$$As^2e^{st} + \frac{AR}{L}se^{st} + \frac{A}{LC}e^{st} = 0 \quad \longrightarrow \quad Ae^{st} \left(s^2 + \frac{R}{L}s + \frac{1}{LC} \right) = 0$$

Source Free RLC Circuit (contd.)

$$\underbrace{Ae^{st}}_{= i} \left(s^2 + \frac{R}{L}s + \frac{1}{LC} \right) = 0 \quad \longrightarrow$$

$$s^2 + \frac{R}{L}s + \frac{1}{LC} = 0$$

characteristic equation
of the differential
equation

- Initial values of current and its derivative can be obtained from:

$$i(0) = I_0$$

Furthermore, from KVL:

$$Ri(0) + L \frac{di(0)}{dt} + V_0 = 0$$



$$\frac{di(0)}{dt} = -\frac{1}{L}(RI_0 + V_0)$$

$$s_1 = -\frac{R}{2L} + \sqrt{\left(\frac{R}{2L}\right)^2 - \frac{1}{LC}}$$

$$s_2 = -\frac{R}{2L} - \sqrt{\left(\frac{R}{2L}\right)^2 - \frac{1}{LC}}$$

- A more compact form:**

$$s_1 = -\alpha + \sqrt{\alpha^2 - \omega_0^2},$$

$$s_2 = -\alpha - \sqrt{\alpha^2 - \omega_0^2}$$

$$\alpha = \frac{R}{2L}, \quad \omega_0 = \frac{1}{\sqrt{LC}}$$

Source Free RLC Circuit (contd.)

- s_1 and s_2 are called *natural frequencies*.
- ω_0 is known as the *resonant frequency* or strictly as the *undamped natural frequency*.
- α is the damping factor.

$$s^2 + \frac{R}{L}s + \frac{1}{LC} = 0 \quad \Rightarrow \quad s^2 + 2\alpha s + \omega_0^2 = 0$$

The two values of s indicate that there are two possible solutions for i .

$$i_1 = A_1 e^{s_1 t}, \quad i_2 = A_2 e^{s_2 t}$$

Original equation

$$\frac{d^2 i}{dt^2} + \frac{R}{L} \frac{di}{dt} + \frac{i}{LC} = 0$$

linear equation and therefore any linear combination of the two distinct solutions i_1 and i_2 is also a solution

$$i(t) = A_1 e^{s_1 t} + A_2 e^{s_2 t}$$

constants A_1 and A_2 are determined from the initial values $i(0)$ and $\frac{di(0)}{dt}$

Source Free RLC Circuit (contd.)

- three types of solutions possible:

1. If $\alpha > \omega_0$, we have the *overdamped* case.
2. If $\alpha = \omega_0$, we have the *critically damped* case.
3. If $\alpha < \omega_0$, we have the *underdamped* case.

Overdamped Case ($\alpha > \omega_0$): $C > 4L/R^2$



Leads both roots s_1 and s_2 to be negative and real

$$i(t) = A_1 e^{s_1 t} + A_2 e^{s_2 t}$$

decays and approaches zero with increase in t .

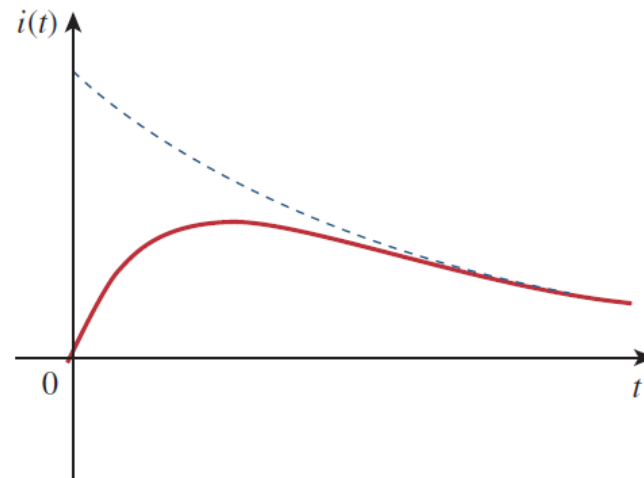

Source Free RLC Circuit (contd.)

Critically Damped Case ($\alpha = \omega_0$): $\dot{C} = 4L/R^2$

$$s_1 = s_2 = -\alpha = -\frac{R}{2L} \quad \Rightarrow \quad i(t) = A_1 e^{-\alpha t} + A_2 t e^{-\alpha t} = A_3 e^{-\alpha t}$$

$$A_3 = A_1 + A_2$$

Not a solution as two initial conditions can't be satisfied with single constant.

Therefore, the assumption of an exponential solution is incorrect for the special case of critical damping.

- For $\alpha = \omega_0 = R/2L$:

$$\frac{d^2 i}{dt^2} + 2\alpha \frac{di}{dt} + \alpha^2 i = 0 \quad \Rightarrow \quad \frac{d}{dt} \left(\frac{di}{dt} + \alpha i \right) + \alpha \left(\frac{di}{dt} + \alpha i \right) = 0$$

Let: $f = \frac{di}{dt} + \alpha i \quad \Rightarrow \quad \frac{df}{dt} + \alpha f = 0$ a first-order differential equation with solution

Source Free RLC Circuit (contd.)

- Solution of the form: $f = A_1 e^{-\alpha t}$,

$$\frac{di}{dt} + \alpha i = A_1 e^{-\alpha t} \quad \xrightarrow{\text{Green Arrow}} \quad e^{\alpha t} \frac{di}{dt} + e^{\alpha t} \alpha i = A_1 \quad \xrightarrow{\text{Yellow Arrow}} \quad \frac{d}{dt}(e^{\alpha t} i) = A_1$$

$$e^{\alpha t} i = A_1 t + A_2 \quad \xrightarrow{\text{Integrate}}$$

$$i = (A_1 t + A_2) e^{-\alpha t}$$

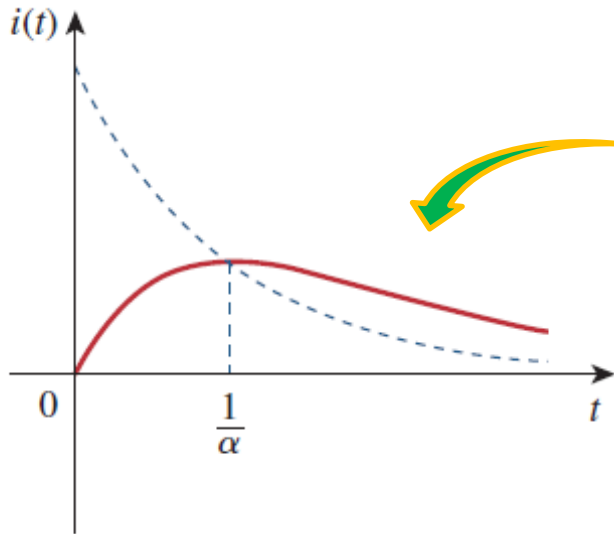

reaches a maximum value of e^{-1}/α at $t = 1/\alpha$, one time constant, and then decays to zero.

Source Free RLC Circuit (contd.)

Underdamped Case ($\alpha < \omega_0$): $C < 4L/R^2$

$$s_1 = -\alpha + \sqrt{-(\omega_0^2 - \alpha^2)} = -\alpha + j\omega_d$$

$$s_2 = -\alpha - \sqrt{-(\omega_0^2 - \alpha^2)} = -\alpha - j\omega_d$$

Damping Frequency

$$\omega_d = \sqrt{\omega_0^2 - \alpha^2}$$

$$\begin{aligned} i(t) &= A_1 e^{-(\alpha - j\omega_d)t} + A_2 e^{-(\alpha + j\omega_d)t} \\ &= e^{-\alpha t} (A_1 e^{j\omega_d t} + A_2 e^{-j\omega_d t}) \end{aligned}$$

$$\begin{aligned} i(t) &= e^{-\alpha t} [A_1 (\cos \omega_d t + j \sin \omega_d t) + A_2 (\cos \omega_d t - j \sin \omega_d t)] \\ &= e^{-\alpha t} [(A_1 + A_2) \cos \omega_d t + j(A_1 - A_2) \sin \omega_d t] \end{aligned}$$

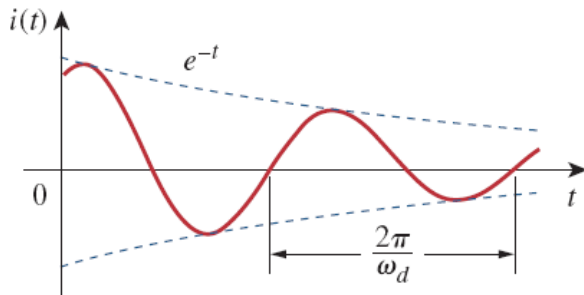

Natural response for this case is exponentially damped and oscillatory in nature.

Source Free RLC Circuit (contd.)

Once the inductor current $i(t)$ is found for the RLC series circuit, other circuit quantities such as individual element voltages can easily be found. For example, the resistor voltage is $v_R = iR$ and the inductor voltage is $L \frac{di}{dt}$.

- The behavior of such RLC network is captured by the idea of *damping*, which is the gradual loss of the initial stored energy, evidenced by the continuous decrease in the amplitude of the response. The damping effect is due to the presence of resistance R .
- By adjusting the value of R , the response may be made undamped, overdamped, critically damped, or underdamped.
- Oscillatory response is possible due to the presence of the two types of storage elements. Presence of both L and C allows the flow of energy back and forth between the two.
- it is difficult to tell from the waveforms the difference between the overdamped and critically damped responses. The critically damped case is the borderline between the underdamped and overdamped cases and it decays the fastest.

Example – 6

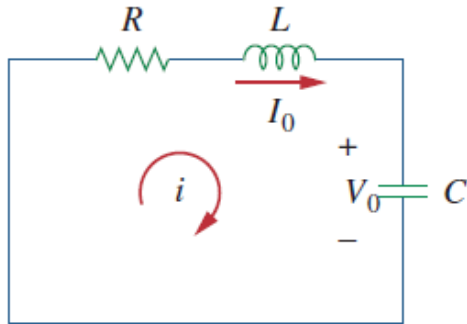

In this circuit: $R=40\Omega$, $L=4\text{H}$, $C=1/4\text{F}$. Calculate the characteristic roots of the circuit. Is the natural response overdamped, underdamped, or critically damped?

Example – 7

The current in an RLC circuit is described by:

$$\frac{d^2 i}{dt^2} + 10 \frac{di}{dt} + 25i = 0$$

If $i(0)=10$ and $di(0)/dt=0$ then find $i(t)$ for $t>0$.

Example – 8

The differential equation that describes the voltage in an RLC network is:

$$\frac{d^2 v}{dt^2} + 5 \frac{dv}{dt} + 4v = 0$$

Given that $v(0)=0$, $dv(0)/dt=10$, obtain $v(t)$.

Example – 9

If $R = 20\Omega$, $L = 0.6\text{H}$, what value of C will make an RLC series circuit:

- (a) overdamped,
- (b) critically damped,
- (c) underdamped?

Example – 10

For the following circuit, calculate the value of R needed to have a critically damped response.

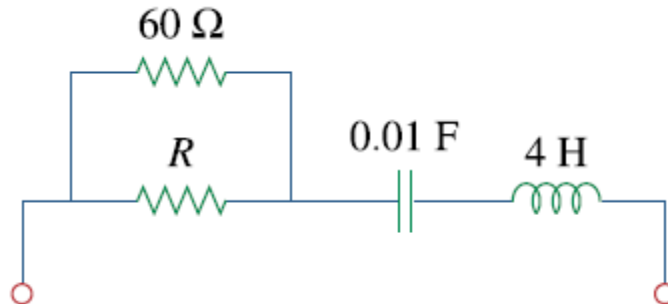

Example – 11

The switch in the circuit moves from position A to position B at $t = 0$. Find $v(t)$ for $t > 0$.

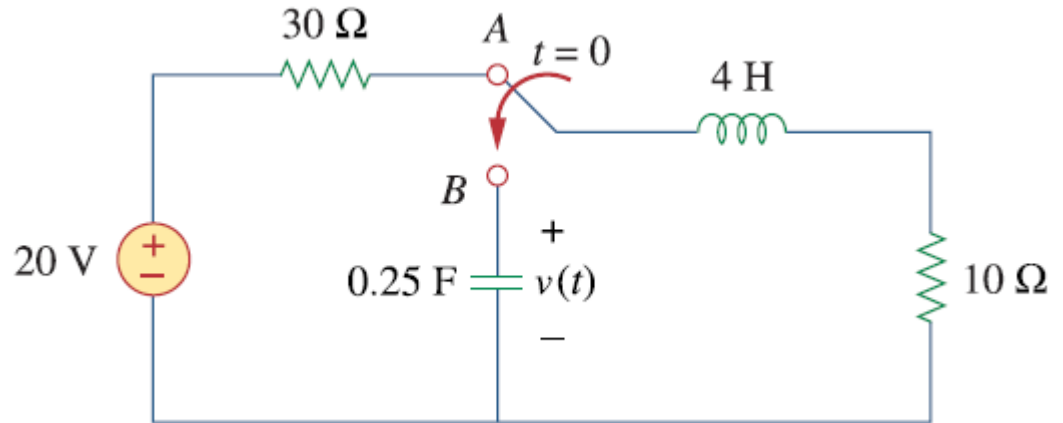

Example – 12

The responses of a series RLC circuit are:

$$v_c(t) = 30 - 10e^{-20t} + 30e^{-10t} \text{ V}$$

$$i_L(t) = 40e^{-20t} - 60e^{-10t} \text{ mA}$$

where v_c and i_L are the capacitor voltage and inductor current, respectively. Determine the values of R , L , and C .