

Lecture – 10

Date: 08.09.2016

- AC Power Analysis (contd.)

Apparent Power and Power Factor

$$v(t) = V_m \cos(\omega t + \theta_v)$$

$$i(t) = I_m \cos(\omega t + \theta_i)$$

Average Power: $P = \frac{1}{2} V_m I_m \cos(\theta_v - \theta_i)$

$$P = V_{\text{rms}} I_{\text{rms}} \cos(\theta_v - \theta_i) = S \cos(\theta_v - \theta_i)$$

$$S = V_{\text{rms}} I_{\text{rms}} \quad \leftarrow \text{apparent power}$$

$$\cos(\theta_v - \theta_i) \quad \leftarrow \text{Power factor}$$

The apparent power is so called because it seems apparent that the power should be the voltage-current product, by analogy with dc resistive circuits. It is measured in volt-amperes or VA to distinguish it from the average or real power, which is measured in watts.

power factor may be seen as that factor by which the apparent power must be multiplied to obtain the real or average power. The value of pf ranges between zero and unity.

Example – 1

A series-connected load draws a current $i(t) = 4\cos(100\pi t + 10^\circ)\text{A}$ when the applied voltage is $v(t) = 120\cos(100\pi t - 120^\circ)$. Find the apparent power and the power factor of the load. Determine the element values that form the series-connected load.

Complex Power

Power engineers use the term *complex power* to find the total effect of parallel loads. It is important in power analysis as it contains *all* the information pertaining to the power absorbed by a given load.

$$\begin{aligned}
 \mathbf{S} &= \frac{1}{2} \mathbf{V} \mathbf{I}^* && \rightarrow && \mathbf{S} = \mathbf{V}_{\text{rms}} \mathbf{I}_{\text{rms}}^* && \begin{aligned} \mathbf{V}_{\text{rms}} &= \frac{\mathbf{V}}{\sqrt{2}} = V_{\text{rms}} \angle \theta_v \\ \mathbf{I}_{\text{rms}} &= \frac{\mathbf{I}}{\sqrt{2}} = I_{\text{rms}} \angle \theta_i \end{aligned} \\
 &&& \rightarrow && \mathbf{S} = V_{\text{rms}} I_{\text{rms}} \angle \theta_v - \theta_i && \\
 &&& && && = V_{\text{rms}} I_{\text{rms}} \cos(\theta_v - \theta_i) + j V_{\text{rms}} I_{\text{rms}} \sin(\theta_v - \theta_i)
 \end{aligned}$$

- the magnitude of the complex power is the apparent power \rightarrow the complex power is measured in volt-amperes (VA).
- the angle of the complex power is the power factor angle.

We know: $\mathbf{Z} = \frac{\mathbf{V}}{\mathbf{I}} = \frac{V_{\text{rms}}}{I_{\text{rms}}} = \frac{V_{\text{rms}}}{I_{\text{rms}}} \angle \theta_v - \theta_i$

$$\mathbf{S} = I_{\text{rms}}^2 \mathbf{Z} = \frac{V_{\text{rms}}^2}{\mathbf{Z}^*} = \mathbf{V}_{\text{rms}} \mathbf{I}_{\text{rms}}^*$$

Complex Power (contd.)

$$\mathbf{S} = I_{\text{rms}}^2 \mathbf{Z} = \frac{V_{\text{rms}}^2}{\mathbf{Z}^*} = \mathbf{V}_{\text{rms}} \mathbf{I}_{\text{rms}}^* \quad \longrightarrow \quad \mathbf{S} = I_{\text{rms}}^2 (R + jX) = P + jQ$$

$$P = \text{Re}(\mathbf{S}) = I_{\text{rms}}^2 R \quad \longrightarrow \quad P = V_{\text{rms}} I_{\text{rms}} \cos(\theta_v - \theta_i)$$

$$Q = \text{Im}(\mathbf{S}) = I_{\text{rms}}^2 X \quad \longrightarrow \quad Q = V_{\text{rms}} I_{\text{rms}} \sin(\theta_v - \theta_i)$$

- The real power P is the average power in watts delivered to a load; it is the only useful power. It is the actual power dissipated by the load.
- The reactive power Q is a measure of the energy exchange between the source and the reactive part of the load. The unit of Q is the *volt-ampere reactive* (VAR).
- The energy storage elements neither dissipate nor supply power, but exchange power back and forth with the rest of the network.
- Similarly, the reactive power is being transferred back and forth between the load and the source. It represents a lossless interchange between the load and the source.

Complex Power (contd.)

1. $Q = 0$ for resistive loads (unity pf).
2. $Q < 0$ for capacitive loads (leading pf).
3. $Q > 0$ for inductive loads (lagging pf).

Summary: the complex power allows determination of the real and reactive powers directly from voltage and current phasors.

$$\text{Complex Power} = \mathbf{S} = P + jQ = \mathbf{V}_{\text{rms}}(\mathbf{I}_{\text{rms}})^*$$

$$= |\mathbf{V}_{\text{rms}}| |\mathbf{I}_{\text{rms}}| \angle \theta_v - \theta_i$$

$$\text{Apparent Power} = S = |\mathbf{S}| = |\mathbf{V}_{\text{rms}}| |\mathbf{I}_{\text{rms}}| = \sqrt{P^2 + Q^2}$$

$$\text{Real Power} = P = \text{Re}(\mathbf{S}) = S \cos(\theta_v - \theta_i)$$

$$\text{Reactive Power} = Q = \text{Im}(\mathbf{S}) = S \sin(\theta_v - \theta_i)$$

$$\text{Power Factor} = \frac{P}{S} = \cos(\theta_v - \theta_i)$$

Complex Power (contd.)

- *power triangle*: S , P , and Q forms this triangle.

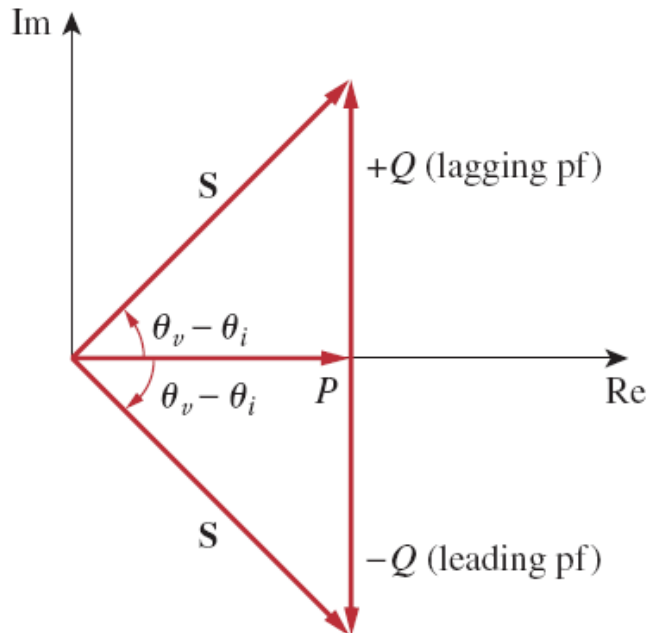

- when S lies in the first quadrant, we have an inductive load and a lagging pf.
- When S lies in the fourth quadrant, the load is capacitive and the pf is leading.
- It is also possible for the complex power to lie in the second or third quadrant.
- This requires that the load impedance have a negative resistance, which is possible with active circuits.

Example – 2

A 110-V rms, 60-Hz source is applied to a load impedance \mathbf{Z} . The apparent power entering the load is 120 VA at a power factor of 0.707 lagging.

- Calculate the complex power.
- Find the rms current supplied to the load.
- Determine \mathbf{Z} .
- Assuming that $\mathbf{Z} = R + j\omega L$, find the values of R and L .

Example – 3

Find the complex power delivered by v_s to this network.
Let $v_s = 100 \cos(2000t)$ V.

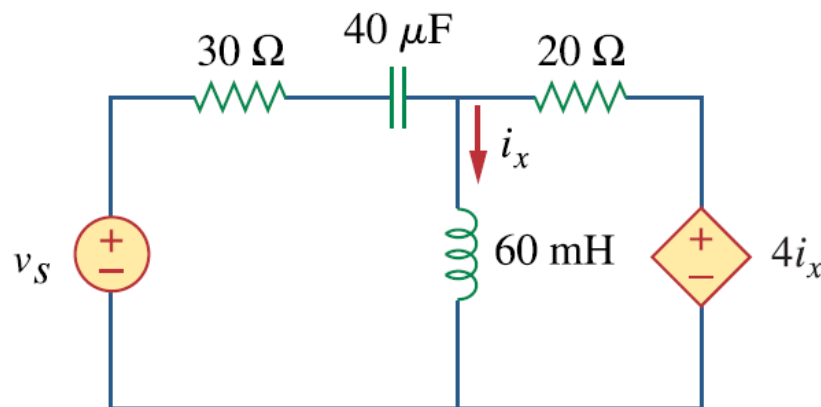

Conservation of AC Power

- Let us consider a parallel and another a series network.

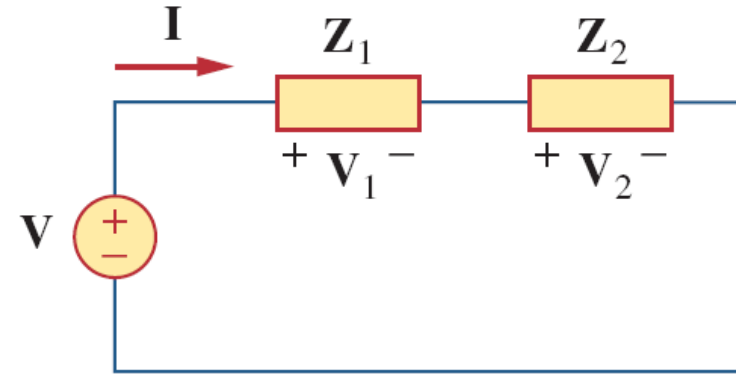
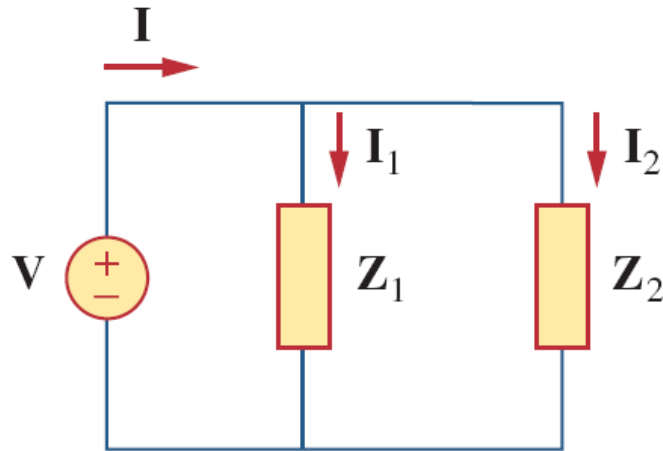

$$S = VI^* = V(I_1^* + I_2^*) = VI_1^* + VI_2^* = S_1 + S_2$$

$$S = VI^* = (V_1 + V_2)I^* = V_1I^* + V_2I^* = S_1 + S_2$$

whether the loads are connected in series or in parallel (or in general),
the total power *supplied* by the source equals the total power
delivered to the load

Conservation of AC Power (contd.)

- in general, for a source connected to N loads: $S = S_1 + S_2 + \dots + S_N$

the total complex power in a network is the sum of the complex powers of the individual components. (This is also true of real power and reactive power.)

From this we imply that the real (or reactive) power flow from sources in a network equals the real (or reactive) power flow into the other elements in the network.

Example – 4

Obtain the complex power delivered to the 10-k Ω resistor.

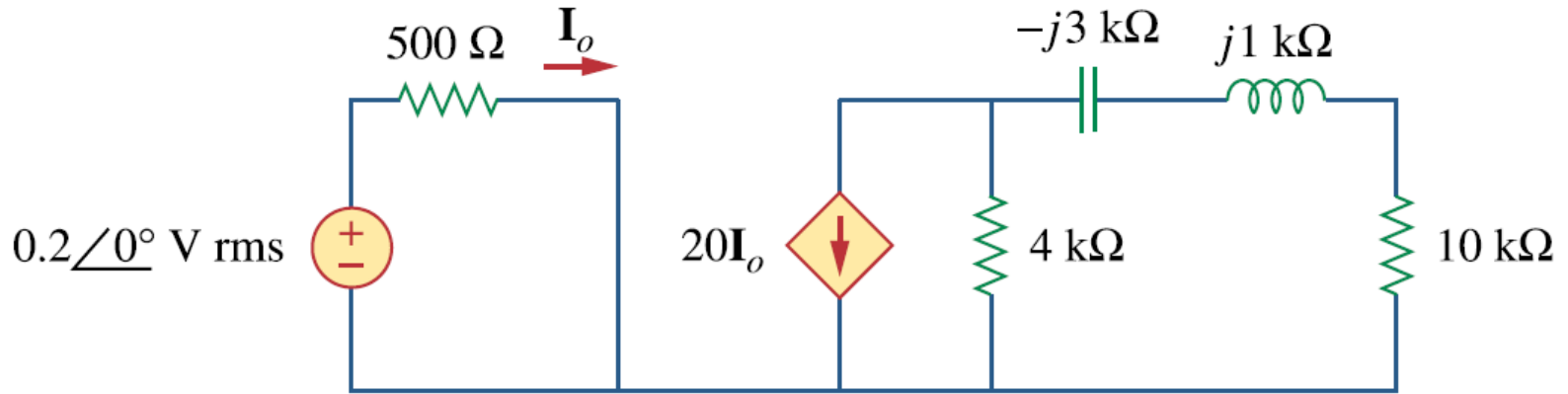

Power Factor Correction

- Most domestic loads (such as washing machines, air conditioners, and refrigerators) and industrial loads (such as induction motors) are inductive and operate at a low lagging power factor.
- Apparently, the inductive nature of the load cannot be changed, but one can increase its power factor.

The process of increasing the power factor without altering the voltage or current to the original load is known as **power factor correction**.

Since most loads are inductive, a load's power factor is improved or corrected by incorporating a capacitor in parallel with the load.

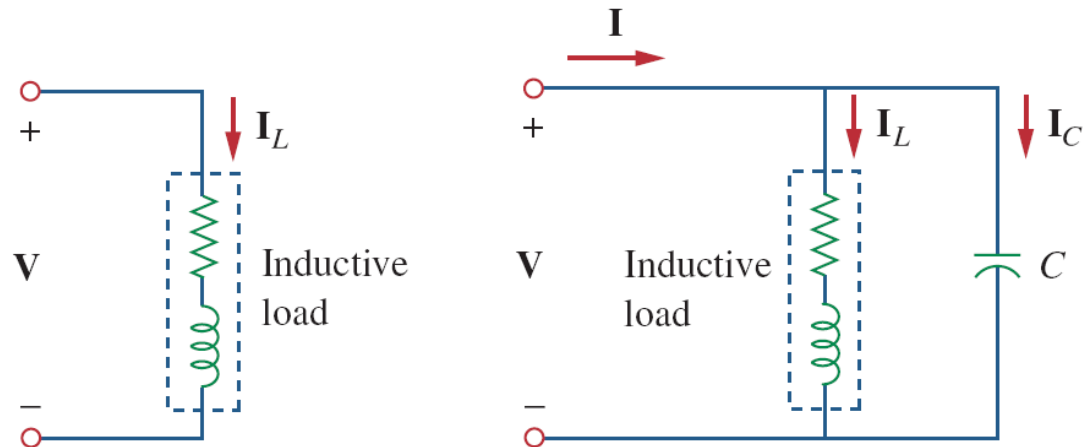

Power Factor Correction (contd.)

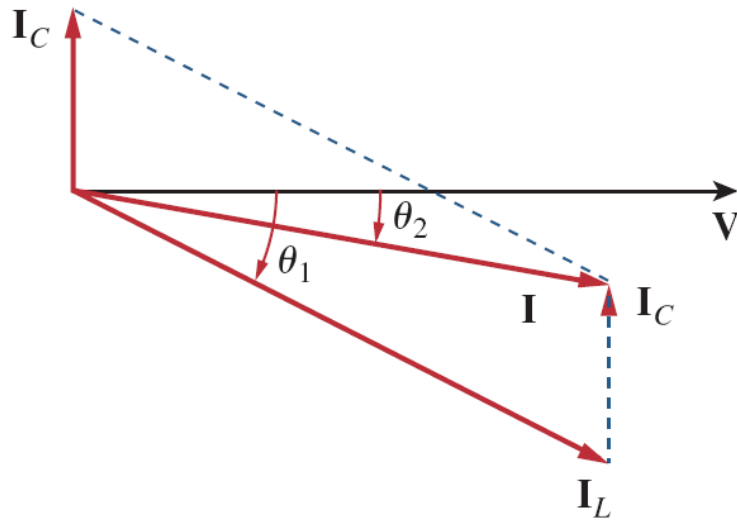

- the magnitudes of the vectors that with the same supplied voltage, the original circuit draws larger current than the current I drawn by the modified circuit.
- Power companies charge more for larger currents, because they result in increased power losses (by a squared factor).
- It is beneficial to both the power company and the consumer that every effort is made to minimize current level or keep the power factor as close to unity as possible.
- By choosing a suitable size for the capacitor, the current can be made to be completely in phase with the voltage, implying unity power factor.

Power Factor Correction (contd.)

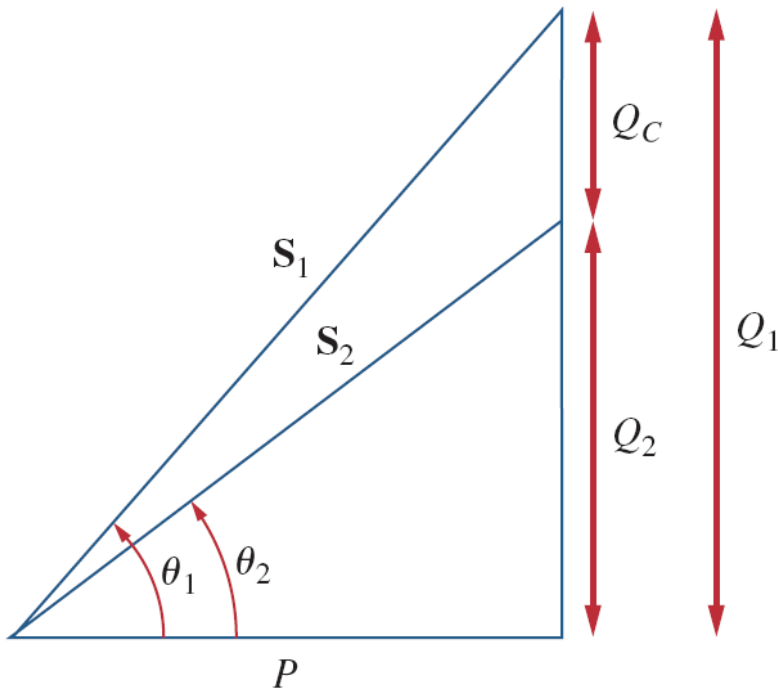

Consider the power triangle:

- If the original inductive load has apparent power S_1 then

$$P = S_1 \cos \theta_1 \quad Q_1 = S_1 \sin \theta_1 = P \tan \theta_1$$

- the new reactive power after pf correction

$$Q_2 = P \tan \theta_2$$

- The reduction in the reactive power

$$Q_C = Q_1 - Q_2 = P(\tan \theta_1 - \tan \theta_2)$$

$$Q_C = V_{\text{rms}}^2 / X_C = \omega C V_{\text{rms}}^2 \quad \rightarrow \quad C = \frac{Q_C}{\omega V_{\text{rms}}^2} = \frac{P(\tan \theta_1 - \tan \theta_2)}{\omega V_{\text{rms}}^2}$$

the real power P dissipated by the load is not affected by the power factor correction because the average power due to the capacitance is zero.

Electricity Consumption Cost

- The concept of power factor is included in the calculations. Loads with low power factors are costly to serve because they require large currents.
- The ideal situation would be to draw minimum current from a supply so that $S = P, Q = 0, \text{ and } pf = 1$.
- A load with **nonzero Q** means that energy flows back and forth between the load and the source, giving rise to **additional power losses**.
- Therefore, power companies encourage their customers to have power factors as close to unity as possible and penalize some customers who do not improve their load power factors.
- Utility companies use different methods for charging customers but irrespective of methods there are always two-parts in that.
- The first part is fixed and corresponds to the cost of generation, transmission, and distribution of electricity to meet the load requirements of the consumers. This part of the tariff is generally expressed as a certain price per kW of maximum demand.
- Or it may be based on kVA of maximum demand, to account for the power factor (pf) of the consumer.

Electricity Consumption Cost (contd.)

- The second part is proportional to the energy consumed in kWh.
- It may be in graded form, for example, the first 100 kWh at 16 cents/kWh, the next 200 kWh at 10 cents/kWh and so forth.....
- Thus, the bill is determined based on the equation:

$$\text{Total Cost} = \text{Fixed Cost} + \text{Cost of Energy}$$

Example – 5

A manufacturing industry consumes 200 MWh in one month. If the maximum demand is 1,600 kW, calculate the electricity bill based on the following two-part rate:

Demand charge: \$5.00 per month per kW of billing demand.

Energy charge: 8 cents per kWh for the first 50,000 kWh, 5 cents per kWh for the remaining energy.